

Address:
Block 9,Shuiwei Ind Zone,Shuiwei New
Village,Dalang,Longhua,Shenzhen,
Guangdong,China 518109

Tel:(86)755-28121370/ 28121371/28109416/28109419
Fax: (86)755-28109417
E-mail: rd@horn.com.cn
Website:www.horn.com.cn

CUSTOMER:

APPROVAL SHEET

PRODUCT NAME	PART NUMBER	DIMENSION	REMARK
Electret Condenser Microphone	EM4015SMT-44BC10&33-G	Ø4.0×1.5(mm)	D.S.PCB

APPROVED BY	CHECKED BY	ISSUED BY

APPROVED BY:

DATE:

PART NUMBER : EM4015SMT-44BC10&33-G

Address:
Block 9, Shuiwei Ind Zone, Shuiwei New
Village, Dalang, Longhua, Shenzhen,
Guangdong, China 518109

Tel: (86)755-28121370/ 28121371/28109416/28109419
Fax: (86)755-28109417
E-mail: rd@horn.com.cn
Website: www.horn.com.cn

SPECIFICATION

Item	Symbol	Test conditions	Min	Standard	Max	Unit
Sensitivity	S	f=1KHz. Pin=1Pa	-47	-44	-41	dB <small>0dB=1V/Pa</small>
Directivity	Omnidirectional					
Impedance	Zout				2.2	K Ω
Input sound pressure level	S.P.L				100	dB
Operation voltage	Vs	-	1.0	2.0	10	V
Current consumption	I	f=1KHz. Pin=1Pa			500	uA
Sensitivity reduction	ΔS	f=1KHz. Pin=1Pa. Vs=2.0→1.5V			-3	dB
S/N ratio	S/N(A)	f=1KHz. Pin=1Pa. A=curve	58			dB

Measurement Circuit (Test Condition Vs=2.0V RL=2.2KΩ

Ta=20°C R.H=65%)

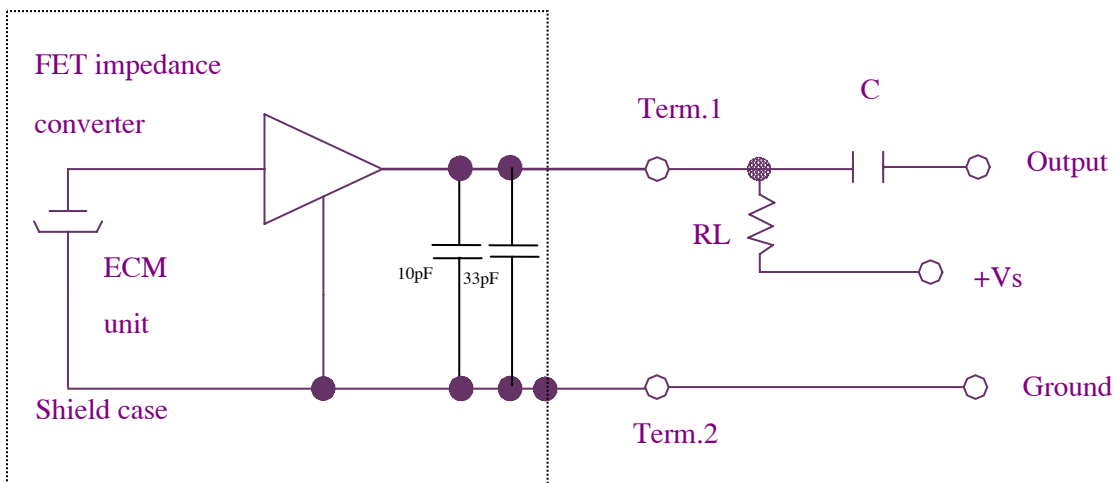

PART NUMBER : EM4015SMT-44BC10&33-G

Address:
Block 9, Shuiwei Ind Zone, Shuiwei New
Village, Dalang, Longhua, Shenzhen,
Guangdong, China 518109

Tel: (86)755-28121370/ 28121371/28109416/28109419
Fax: (86)755-28109417
E-mail: rd@horn.com.cn
Website: www.horn.com.cn

Dimensional Drawing

unit: mm

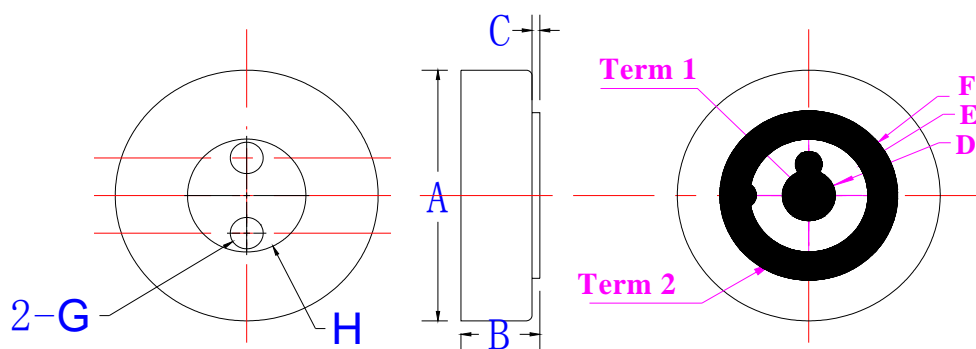

PART	MIN	STANDARD	MAX	REMARK
A	Ø3.9	Ø4.0	Ø4.1	
B	1.3	1.5	1.7	
C	0.1	0.15	0.2	
D	Ø0.7	Ø0.8	Ø0.9	
E	Ø1.7	Ø1.8	Ø1.9	
F	Ø2.5	Ø2.7	Ø2.9	
G	Ø0.45	Ø0.5	Ø0.55	
H	-	Ø1.7	-	

Typical Frequency Response Curve

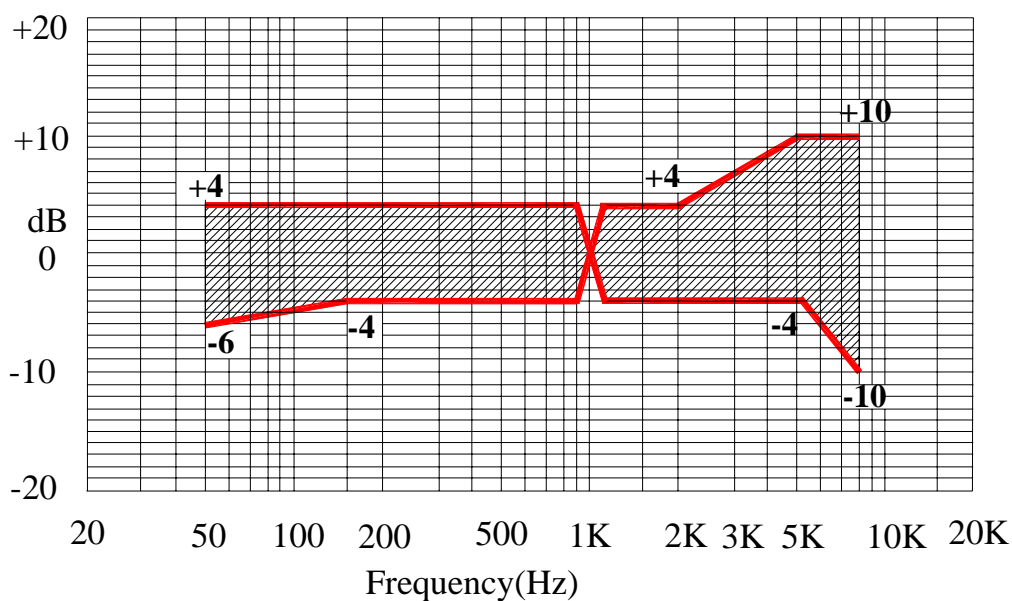

PART NUMBER : EM4015SMT-44BC10&33-G

Address:
Block 9, Shuiwei Ind Zone, Shuiwei New
Village, Dalang, Longhua, Shenzhen,
Guangdong, China 518109

Tel: (86)755-28121370/ 28121371/28109416/28109419
Fax: (86)755-28109417
E-mail: rd@horn.com.cn
Website: www.horn.com.cn

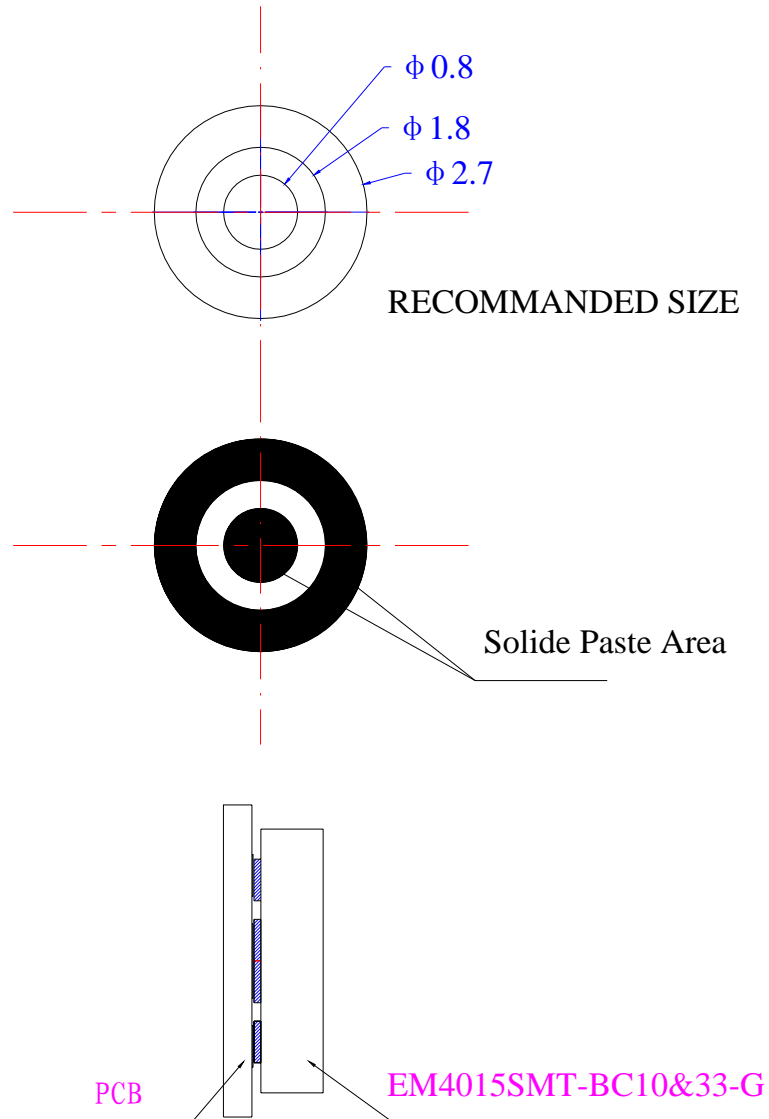

PART NUMBER : EM4015SMT-44BC10&33-G

Address:
Block 9, Shuiwei Ind Zone, Shuiwei New
Village, Dalang, Longhua, Shenzhen,
Guangdong, China 518109

Tel: (86)755-28121370/ 28121371/28109416/28109419
Fax: (86)755-28109417
E-mail: rd@horn.com.cn
Website: www.horn.com.cn

Ambient condition

(1) Operating condition

Ambient temperature: $-20^{\circ}\text{C} \sim +60^{\circ}\text{C}$
Relative humidity: $\leq 85\%$

(2) Storage condition

Ambient temperature: $-20^{\circ}\text{C} \sim +70^{\circ}\text{C}$
Relative humidity: $45\% \sim 75\%$

Reliability Test

1) Vibration Test

To be no interference in operation after vibration of full amplitude 2mm for 30 minutes at three axis, the sensitivity to be within $\pm 3\text{dB}$ from initial sensitivity.

2) Drop test

To be no interference in operation after dropped to concrete floor each time from 1 meter height of three directions in state of packing, the sensitivity to be within $\pm 3\text{dB}$ from initial sensitivity.

3) High Temperature Storage:

To be no interference in operation after high temperature test $100^{\circ}\text{C} \pm 3^{\circ}\text{C}$ for 240 hours. The sensitivity to be within $\pm 3\text{dB}$ from initial sensitivity.

4) Isotherm & Iso-humidity Storage

To be no interference in operation after storage test at temperature $100^{\circ}\text{C} \pm 2^{\circ}\text{C}$ and relative humidity ($93\% \pm 3\%$) for 240 hours, the sensitivity to be within $\pm 3\text{dB}$ from initial sensitivity, the test is performed at temperature 20°C after operation for 6 hours.

5) Low Temperature Storage

To be no interference in operation after test at temperature $-20^{\circ}\text{C} \pm 3^{\circ}\text{C}$ for 240 hours, the sensitivity to be within $\pm 3\text{dB}$ from initial sensitivity.

6) Temperature Cycle Test

After exposure at $55^{\circ}\text{C} \pm 2^{\circ}\text{C}$ for 1 hour, at $20^{\circ}\text{C} \pm 2^{\circ}\text{C}$ for 1 hour, at $-10^{\circ}\text{C} \pm 2^{\circ}\text{C}$ for 1 hour, at $20^{\circ}\text{C} \pm 2^{\circ}\text{C}$ for 1 hour, with 5 cycles. Change of sensitivity within $\pm 3\text{dB}$ from initial measuring should be done after 2 hours exposed to $20^{\circ}\text{C} \pm 2^{\circ}\text{C}$.

7) Collision Test

After collided with the acceleration $100 \pm 10\text{m/s}^2$, at the vertical & horizontal directions for 1000 ± 10 times. at the state of packing. Change of sensitivity within $\pm 3\text{dB}$ from initial.

Address:
Block 9, Shuiwei Ind Zone, Shuiwei New
Village, Dalang, Longhua, Shenzhen,
Guangdong, China 518109

Tel: (86)755-28121370/ 28121371/28109416/28109419
Fax: (86)755-28109417
E-mail: rd@horn.com.cn
Website: www.horn.com.cn

Important Notes

1) To use with an automatic soldering machine-ting and its temperature should be less than 260°C

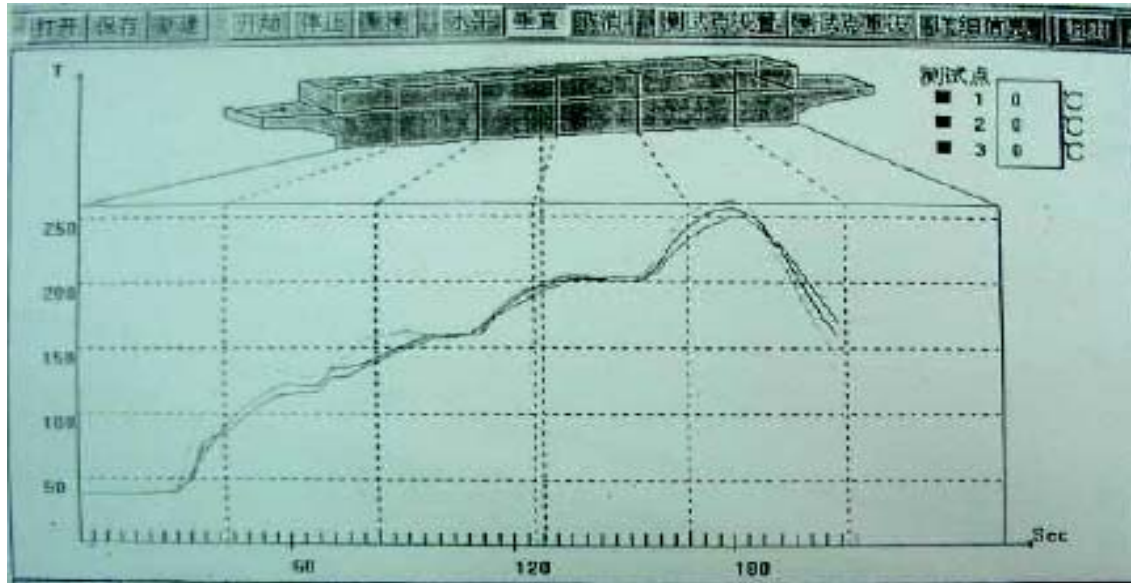

Packaging Detail

Plastic Reel (PS) :

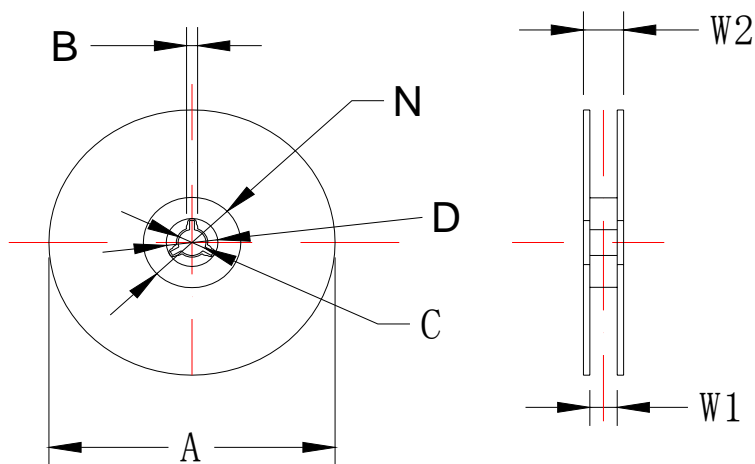

PART NUMBER : EM4015SMT-44BC10&33-G

Address:
Block 9, Shuiwei Ind Zone, Shuiwei New
Village, Dalang, Longhua, Shenzhen,
Guangdong, China 518109

Tel: (86)755-28121370/ 28121371/28109416/28109419
Fax: (86)755-28109417
E-mail: rd@horn.com.cn
Website: www.horn.com.cn

单位: (mm)

PART	MIN	STANDARD	MAX
A	Ø178	Ø180	Ø182
B	2.3	4.3	6.3
C	Ø12.8	Ø13	Ø13.2
D	Ø23.9	Ø24.4	Ø24.9
N	Ø54.5	Ø55	Ø55.5
W1	15.8	16.0	16.2
W2	18.2	18.4	18.6

Carrier Tape:

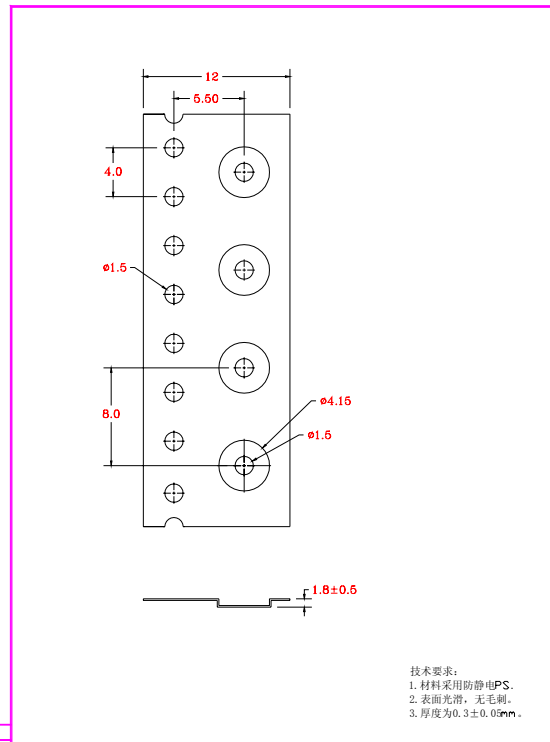

技术要求:
1. 材料采用防静电PS.
2. 表面光滑, 无毛刺.
3. 厚度为0.3±0.05mm.

				编带			材料: PS		
							料号: 01. AF. BD. 401501		
图号	设计	审核	批准	日期	图样标记	单位	重量	比例	HORN 深圳市豪恩电声科技有限公司
版本号	日期	日期	日期		mm		1:2		
A									
				共 1 页		第 1 页			

PART NUMBER : EM4015SMT-44BC10&33-G

Address:
Block 9, Shuiwei Ind Zone, Shuiwei New
Village, Dalang, Longhua, Shenzhen,
Guangdong, China 518109

Tel: (86)755-28121370/ 28121371/28109416/28109419
Fax: (86)755-28109417
E-mail: rd@horn.com.cn
Website: www.horn.com.cn

TEST RESULT OF SAMPLES

NO.	1KHz(dB)	CURRENT (mA)	NOTES
1	-43.6	0.27	(1KHz、0dB=1V/Pa)
2	-44.5	0.27	
3	-44.4	0.20	
4	-44.2	0.28	
5	-44.0	0.28	

Customer:		Date:	2005.08.23
Part number:	EM4015SMT-44BC10&33-G	Sensitivity:	-44±3dB
Test condition:	2.2K Ω 2.0V	Tester:	G1

PART NUMBER : EM4015SMT-44BC10&33-G

Address:
Block 9, Shuiwei Ind Zone, Shuiwei New
Village, Dalang, Longhua, Shenzhen,
Guangdong, China 518109

Tel: (86)755-28121370/ 28121371/28109416/28109419
Fax: (86)755-28109417
E-mail: rd@horn.com.cn
Website: www.horn.com.cn

Certificate of Confirmed Products

Date : Aug.23.2005

NO:

SUPPLIER	HORN	BUYER	
TITLE	ECM	MODEL	EM4015SMT-44BC10&33-G
SIZE	φ 4.0×1.5mm	TEST CONDITION	2.2K Ω 2.0V
QUANTITY	SAMPLE : Pcs		
SPECIFICATION			
Sensitivity	-44 ± 3dB (0dB=1V/Pa. 1KHz)		
Directivity	Omnidirectional		
Impedance	Low impedance		
Standard operation voltage	2.0V		
Operating voltage	1.0-10V		
Current consumption	MAX.500uA		
Maximum input S.P.L	100dB		
S/N ratio	More than 58dB		
Sensitive reduction	Within -3dB at 1.5V		
The test result from customers	Signature: _____ . 2005		
Final confirmed	Pass	Refuse	Accepted basis on
Remarks			

***** The fore must be confirmed by return fax after your test as your best regards! *****

PART NUMBER : EM4015SMT-44BC10&33-G